

1.3.1 Institution integrates cross cutting issues relevant to Gender, Environment and Sustainability, Human Values and Professional Ethics into the Curriculum

1. Gender Sensitivity

1.1 Your Dost www.yourdost.com

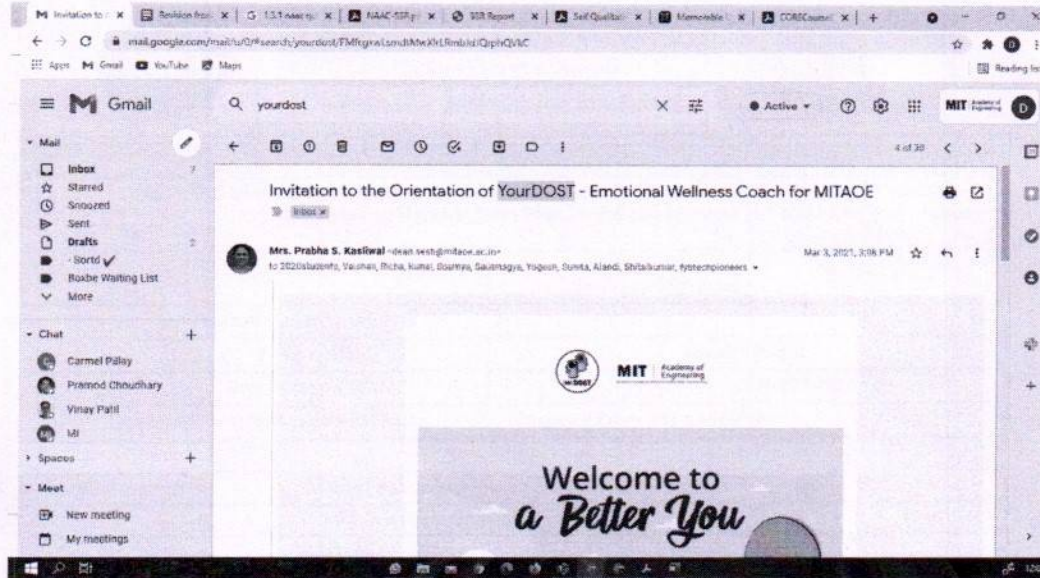

Inauguration

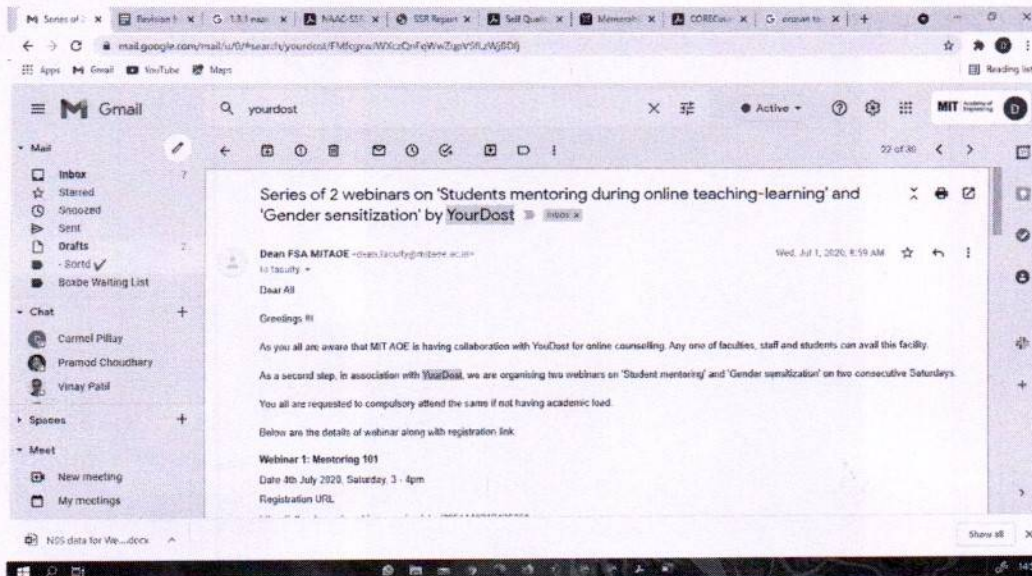

Webinar on Gender Sensitization

NAAC 2021

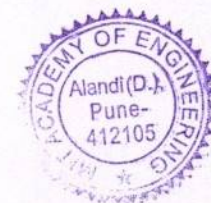

2. Environment and Sustainability:

2.1 Eco San Toilet Building



Preparation of Base



Toilet Building



With Village People



Work Completed

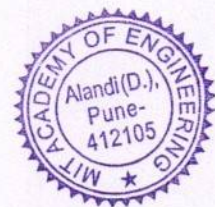

2.2 Unnat Bharat Abhiyan Projects

View Report

Unnat Bharat Abhiyan is inspired by the vision of transformational change in rural development processes by leveraging knowledge institutions to help build the architecture of an Inclusive India. Their mission is conceptualised as a movement to enable processes that connect institutes of higher education with local communities to address the development challenges of rural India through participatory processes and appropriate technologies for accelerating sustainable growth. It also aims to create a virtuous cycle between the society and an inclusive university system by providing knowledge and practices for emerging professions and to upgrade the capabilities of both the public and the private sectors.

1. Vision: Unnat Bharat Abhiyan is inspired by the vision of transformational change in rural development processes by leveraging knowledge institutions to help build the architecture of an Inclusive India.

2. Mission: The Mission of Unnat Bharat Abhiyan is to enable higher educational institutions to work with the people of rural India in identifying development challenges and evolving appropriate solutions for accelerating sustainable growth. It also aims to create a virtuous cycle between society and an inclusive academic system by providing knowledge and practices for emerging professions and to upgrade the capabilities of both the public and the private sectors in responding to the development needs of rural India.

Adopted Village Details

Village	Tahsil	District	Population	Distance from MIT AOE
Dhanore	Khed	Pune, MH	2540	4.1 KM
Markal	Khed	Pune, MH	1530	7 KM
Golegaon	Shirur	Pune, MH	2244	10 KM
Nirgudi	Haveli	Pune, MH	724	4.6 KM
Pimpalgaon	Daund	Pune, MH	5126	8.2 KM

MIT AOE Unnat Bharat Abhiyan Team:

Faculty:

Dr. Shrikant Salve, School of Comp. Engg. & Tech (Institute Coordinator UBA)
Ms. S. S. Shende, School of Chemical Engineering
Ms A Gode, School of Chemical Engineering
Mrs. R. S. Jadhav, School of Mechanical & Civil Engineering
Mrs. S. S. Kabra, School of Electrical Engineering
Dr. Shilpi Bora, School of Engineering Design

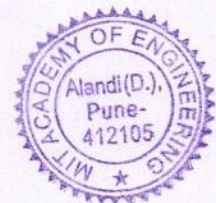

Students:

Omkar Pawar
Rahul Sahoo
Rupesh More
Vishal Shewale
Preeti Bhagade
Geeta Kale

Adarsh Parskar
Kalyani Khudsange
Shrutika Dhabre
Tushar Deore
Shreyas Desai



Fig 1: MIT AOE UBA Team with villagers

Projects Under Unnat Bharat Abhiyan:

1. Augmented Reality based Crop Disease Identification Technique for Indian Farmers
2. Development and Installation of water treatment plant for Indrayani river water at Nirgudi village
3. Design and Development of water supply system for sugarcane field
4. Briquettes from waste

Project 1: Augmented Reality based Crop Disease Identification Technique for Indian Farmers

Understanding the Problem

Agriculture is an important sector of Indian economy and also it is the largest livelihood provider. The agriculture provides employment for more than 50 percent of population and it also contributes about 18 percent of the total gross domestic product (GDP). It is important to increase the level of agriculture development making use of information communication technology (ICT) like smartphones, cloud computing, big data, Augmented Reality, Internet of



Things (IoT) to support the implementation of accuracy, improve crops and their management in agriculture sector. Augmented Reality (AR) technology provides an interactive experience of a real-world environment where the objects that reside in the real-world are 'augmented' by computer-generated perceptual information. This technology can be used to support agriculture for Indian farmers those who uses smart phones. Currently there are various methods used by farmers to identify the crop disease like taking help from farmer friend, pesticide shop person, expert advice from agriculture officer or scientist or agronomist. But, neither all farmers have access to these experts nor these experts are always available. Also, it is inconvenient for farmers because most of the time these helps can take time to reach the farmers. We have proposed a AR-based method to identify the diseases on crop. This technique uses mobile camera to view the crop disease. The crop leaf image capture through camera is matches with the online database of crop disease. Accordingly prediction of disease and preventive measure provided on the mobile screen itself. Now a days majority of farmers uses smart phone, this crop disease prediction mechanism through mobile app using AR technology would be convenient and easily available for the farmers.

Drawbacks in Existing System:

This might not provide the correct solution regarding the type of disease and required treatment.

- (a) after discussion with farmers they told that, "We use strong medicine/ pesticide so that all type of disease gets vanishes". But use of strong pesticide is harmful to our body
- (b) most of the time the agriculture expert is not available
- (c) pesticide shop owner can mislead farmers to increase his sale.



NAAC 2021

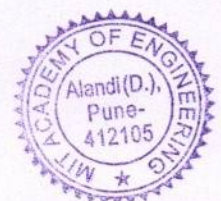

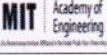

Fig 2: Interaction with Farmers

 उन्नत भारत अभियान Unnat Bharat Abhiyan		
<p><small>This data collection work is the part of an Unnat Bharat Abhiyan initiative of Govt. of India, as an Academic Research work being executed in the MIT Academy of Engineering Alandi, Pune. All your personal information, images & videos taken would be kept confidential and the statistically treated responses will be used for academic research purposes only. Please feel free to share your thoughts and feelings while you answer the questions. Thanks you for your co-operation.</small></p> <p><small>युन्नतभारत अभियान और इंजीनियरिंग अकादमी पुणे येथी एक शैक्षणिक संशोधन कार्य म्हणून अंमलबजावळ करण्यात आलेला हा हेतू संयुक्त कार्य भारत सरकारच्या उन्नत भारत अभियान उपक्रमाचा भाग आहे. घेतलेली आपली सर्व वैयक्तिक माहिती, प्रतिमा आणि व्हिडिओ गोपनीय ठेवण्या जातील आणि शैक्षणिक संशोधन उपयुक्ततेसाठी केवळ शैक्षणिक संशोधन हेतूसाठी वापरण्या जातील. कृपया प्रश्नांची उत्तरे देताना आपले विचार आणि भावना व्यक्त करा. आपल्या सहकार्याबद्दल धन्यवाद.</small></p>		
<p>प्रश्नावली [Questionnaire]</p>		
<p>सहभागी माहिती [Participants information]</p>		
<p>नाव (Name):</p>	<p>लिंग (Gender):</p>	<p>वय (Age):</p>
<p>शिक्षण (Education):</p>	<p>नोकरी (Job):</p>	
<p>आपण किती वर्षे शेती करत आहात? [How long you are doing farming?]</p>		
<p>आपण शेती पूर्ण वेळ / अर्धवेळ करत आहात? [Are you doing farming full time/part time?]</p>		
<p>आपण कोणत्या प्रकारचा फोन वापरत आहात? [What type of phone you are using?]</p>		
<p>स्मार्ट फोन (Smart phone)</p>	<p>सामान्य फोन (Normal phone)</p>	
<p>आपण इंटरनेटवर इंटरनेट वापरता का? [Do you use internet on mobile phone?]</p>		
<p>आपण स्मार्टफोन वापरत असल्यास, आपण कोणत्याही सोशल नेटवर्किंग साइटचा वापर करता? [If you are using smart phone, Do you use any social networking site?]</p>		

During the initial interaction with farmers, we have collected data from farmers through questionnaires which is depicted in figure 2. These questionnaires supported us to identify the exact need of the farmers, their education, use of technology for farming.

Fig 3: Questionnaires

Proposed Solutions

We have developed a prototype of mobile-based application which uses augmented reality technology. This tool/app uses mobile camera to capture the image of infected crop leaf. The crop leaf image is matches with the online database of crop disease. Accordingly prediction of disease and preventive measure provided on the mobile screen itself. The following Figure 2 gives screen-shots of the developed application.

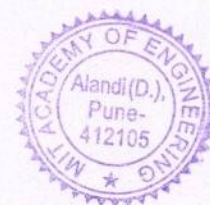
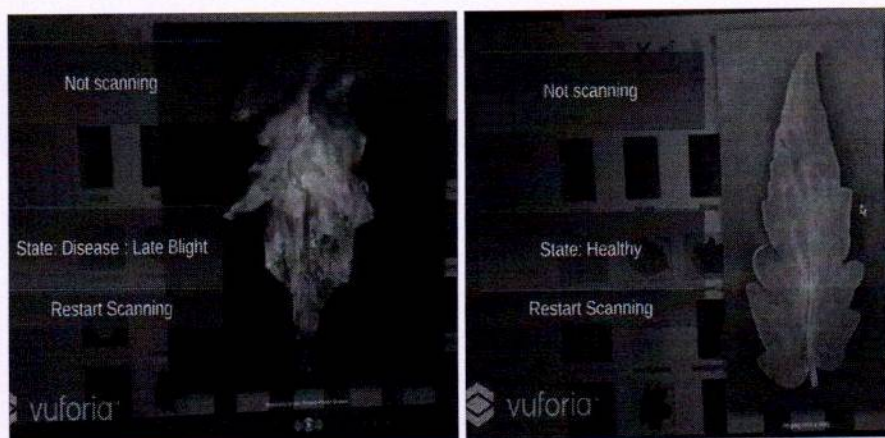

Fig. 4. The screen-shot of AR-based mobile app (a) Screen-shot of infected leaf (b) Screen-shot of non-infected or healthy leaf

Conclusion

We have implemented the prototype of AR-based mobile application which successfully identifies the disease on the crop leaf. We have used image of the infected crop leaf as marker.

The farmer will be able to identify the crop disease immediately using his smart phone. In future we are planning to use the actual crop leaf as marker.

Project 2: Development and Installation of water treatment plant for Indrayani river water at Nirgudi village

Visit Details

We have visited *Nirgudi* village several times, with current visit on 13/03/19 with a team of faculty and students. Our team has done the survey of village. We have discussed with villagers regarding their issues and problems related to water.



Problem Identification

Nirgudi village has small population of 159 households only but still it is a developing village. Major issue faced by the villagers is polluted water. Following are the major issue which villagers wish to get solved is listed,

1. Drinking water arrangement is not proper in the village.
2. Even though Indrayani river passes through the village, its water can not be used for regular use
3. Water Hyacinth has covered the maximum area of river which makes impossible to use river water for irrigation

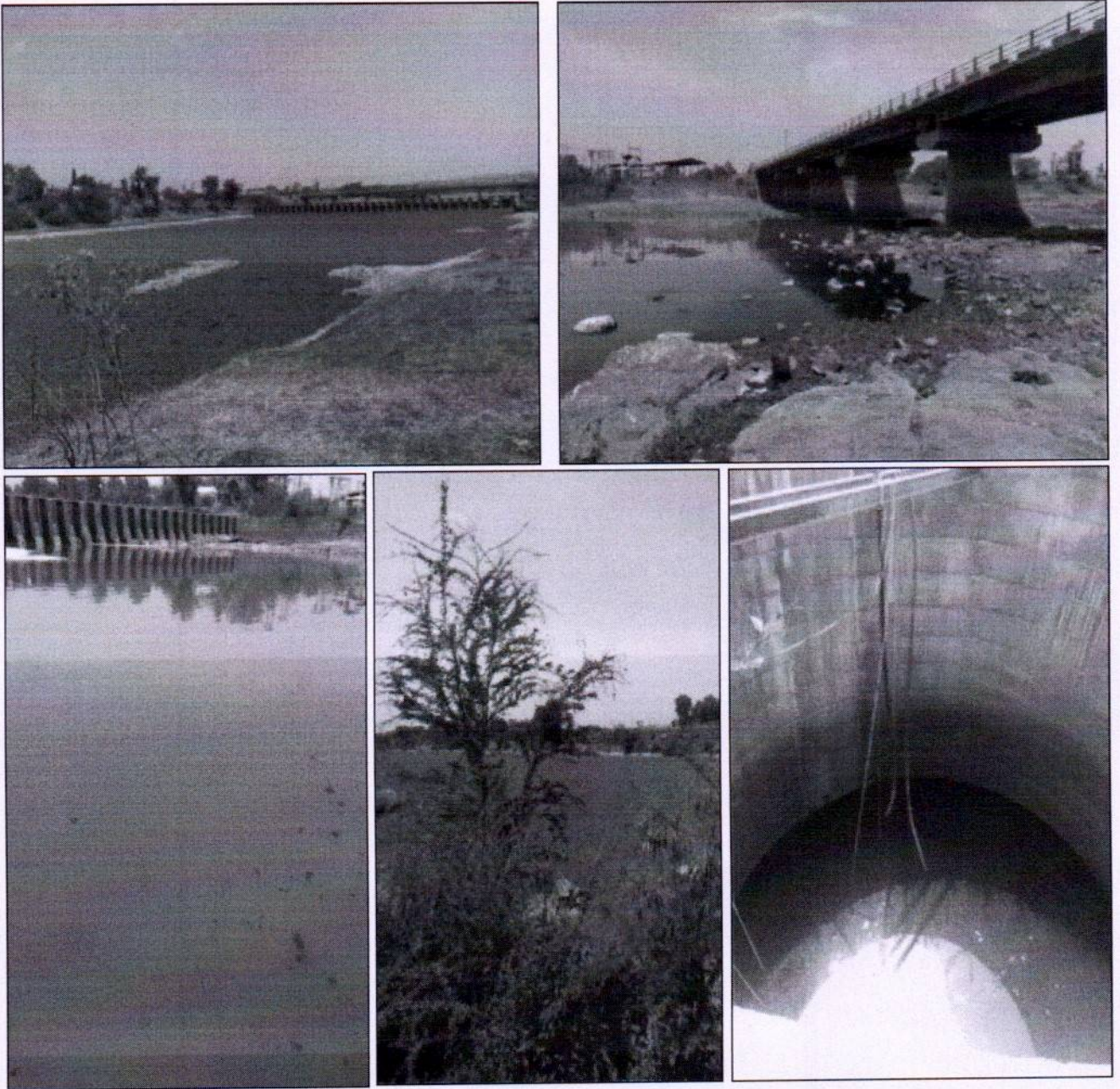

Fig 5: Available Water Sources in Nirgudi Village

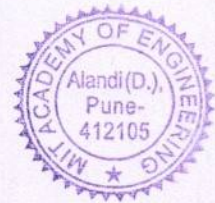

Fig 5: Student Collecting water samples from Indrayani river as well as from a well in the Nirgudi village.

Plan of Action

The sample collected will be taken to the lab experimentations for identification of techniques for treatment of river water to make it drinkable. According to the requirement of water for villagers the scale of the proposed equipment will be decided. Removal and use of water hyacinth for village welfare.

After collection of water presently it is need to have lab testing of water for bacteria, heavy metals and other pollutants, so that we can work on the identification of correct technique of treatment.

Project 3: Design and Development of water supply system for sugarcane field

List of Problems Identified

- 1) Lack of knowledge of government schemes.
- 2) Lack transportation service.
- 3) Zero returns from government schemes.
- 4) Water purification plant is not in working condition.
- 5) Lack of garbage collector.
- 6) Problems for sugar cane lifting.
- 7) Smoke from the *chulha* while in use.
- 8) Theft of solar batteries.

Project 4: Briquettes from Waste

Visit to Dhanori Village

Dhanori is a village panchayat located in the Pune district of Maharashtra state, India. The latitude 18.5939201 and longitude 73.89776929 are the geocoordinate of the Dhanori. Mumbai is the state capital for Dhanori village. It is located around 120.5 kilometer away from Dhanori.. The other nearest state capital from Dhanori is Hyderabad and its distance is 223.0 KM.

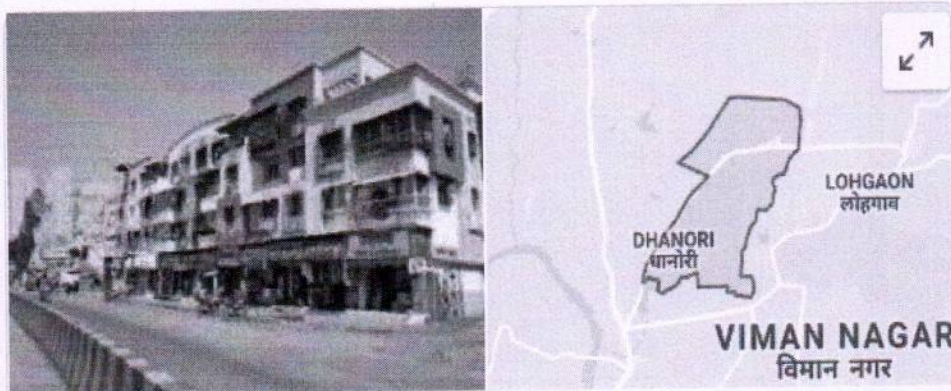

Dhanori

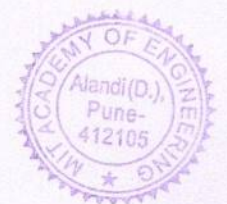

Fig 7: Map of Dhanori Village

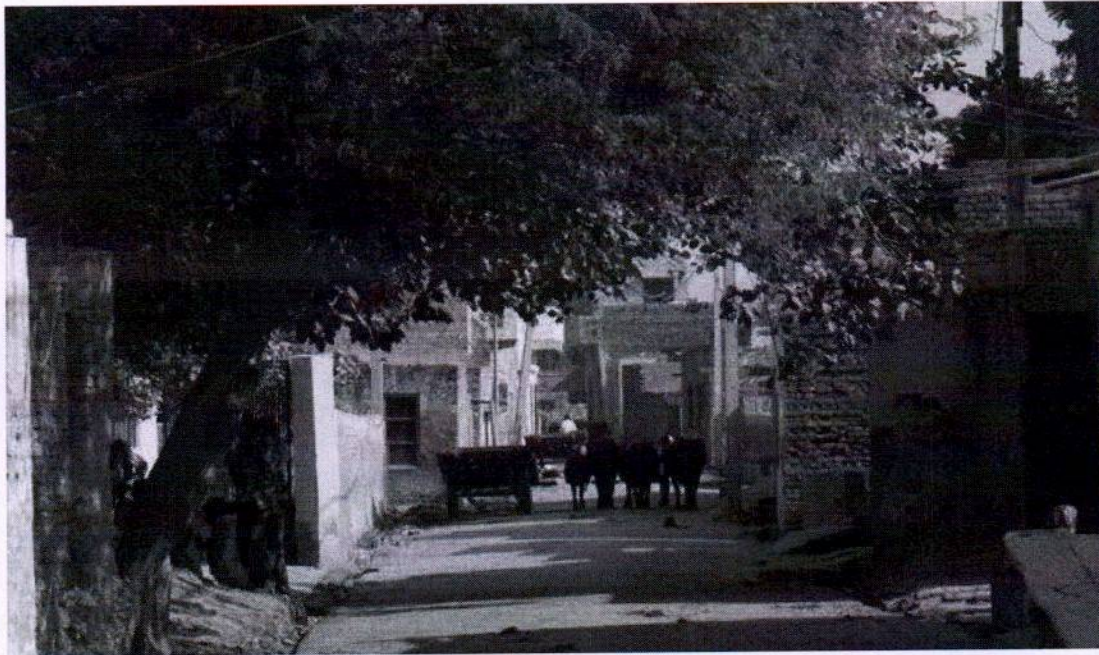

Fig 8: Picture taken at Dhanori Village

	Basics
Population	2775
Population density	319 per km ²
Growth of Population	-3.6%
Sex Ratio	1033

Fig8: Figure depicting Dhanori village population, its density, its growth, sex ratio. There are 698 households in the village and an average 4 persons live in every family.

Exiting Problems in Village:



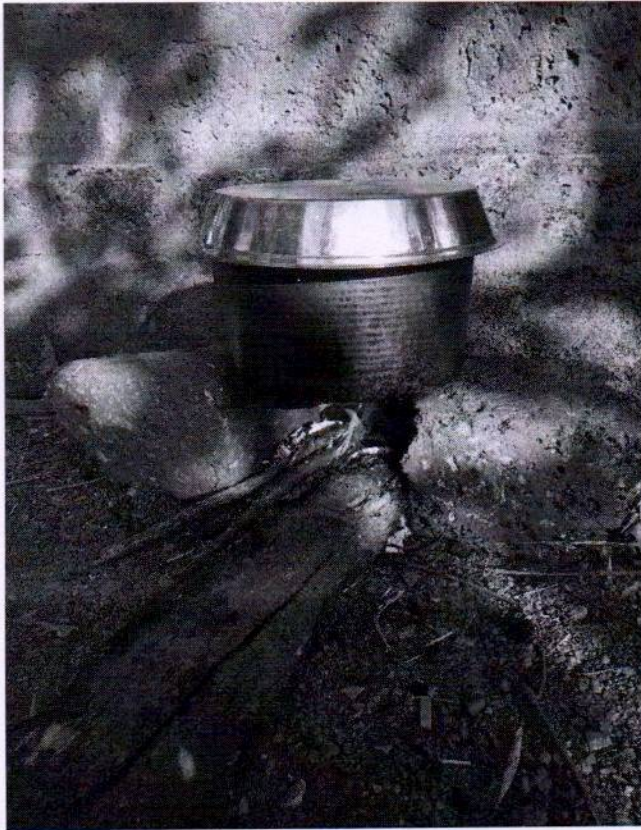

Energy and fuels are the important links in civilization and human development. The issues associated with the use of the fossil fuel, demand and supply gap, ever increasing prices, global warming and other environmental issues made the world to think for alternate sources of energy like solar, wind, ocean and biomass which are the only indigenous renewable energy sources capable of replacing large amount of solid, liquid and gaseous fossil fuel. Wood and coal are used for cooking purposes on a daily basis in villages. This causes depletion of fossil fuels and deforestation. Also, it causes emission of harmful gases (Carbon dioxide, Nitrous oxide, Sulphur dioxide).



Fig 9: Villager using Wood and Coal for Cooking

Proposed Solution

Biomass energy has attracted as one of the potential alternatives as it is an ideal renewable energy source with several advantages like lower sulfur, CO2 neutral emission, and abundant availability generally in the form of waste from agriculture as well as other sources. The population across the globe is increasingly getting inclined towards healthy and processed food products, about one-third of it gets wasted globally and accounted roughly 40-50% for root crops, fruits and vegetables at various stages like agricultural production.

To utilize the organic leftovers of different processes to produce briquettes, which will eliminate the use of wood used in villages for daily purposes.

Briquettes



An energy source that meets such sustainability requirements is fuel briquette. It has advantages over fuel wood in terms of greater heat intensity, cleanliness, convenience in use, and relatively smaller space requirement for storage.

Briquetting process

Briquetting has advantages over fuel wood in terms of greater heat intensity, cleanliness, convenience in use, and relatively smaller space requirement for storage.

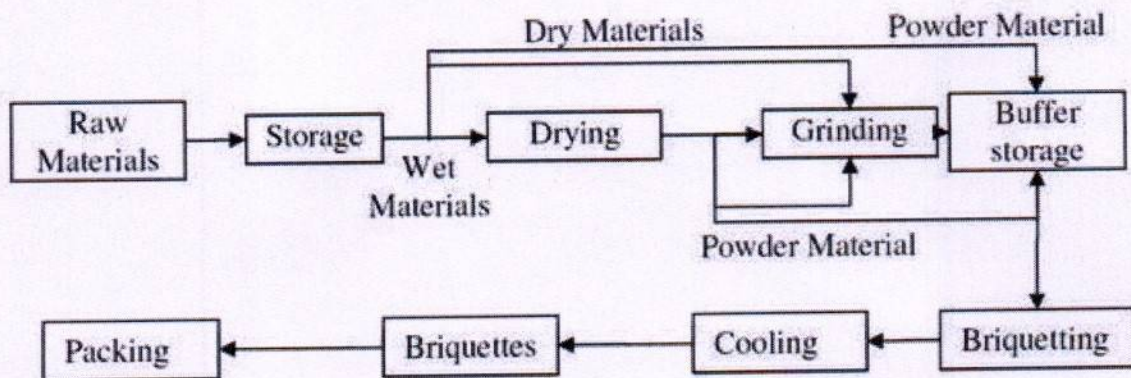
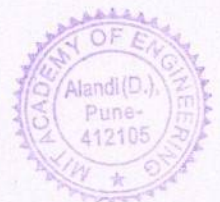

Fig 9: Process of Briquetting
Requirement of Raw Material

Raw Material	Calorific value - Kcal/Kg	Ash %



Groundnut Shell	4500	3.8
Bagasse	4700	1.8
Castor Seed Shells	3860	8
Saw Dust	4400	1.2
Cotton Stalks / Chips	4200	3.01
Bamboo Dust	3700	8
Babul Wood	4707	0.9
Coffee Husk	4200	5.3

Sugarcane Waste

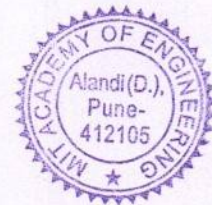
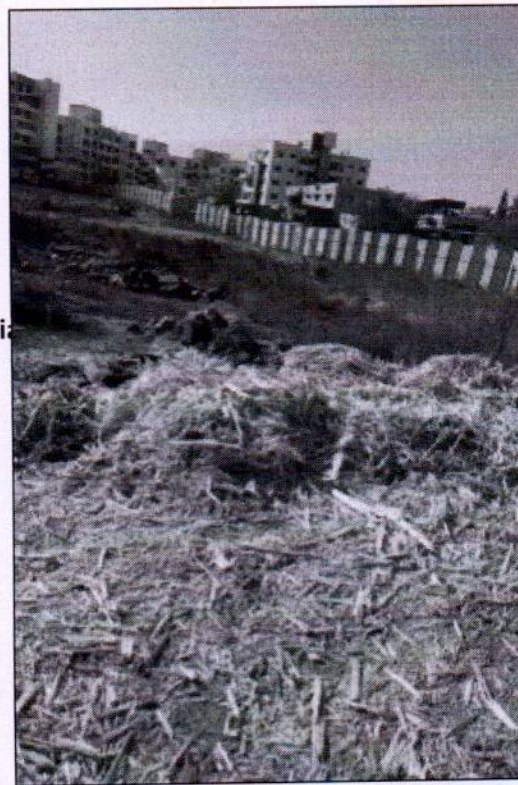

A binder or binding agent is any material or substance that holds or draws other materials together to form a cohesive whole mechanically, chemically, by adhesion or cohesion. In a narrower sense, binders are liquid or dough-like substances that harden by a chemical or physical process and bind fibers, filler powder and other particles added into it. The Common starches we usually use as binders are from maize (corn starch), potato, and wheat. So we are using cornstarch.

Corn starch or maize starch is the starch derived from the corn (maize) grain. The starch is obtained from the endosperm of the kernel. Corn starch is a common food ingredient, used in thickening sauces or soups, and in making corn syrup and other sugars. It has medical uses, such as to supply glucose for people with glycogen storage disease.

CAD Model of Proposed System



Fig 11: CAD Model Screen Shot1



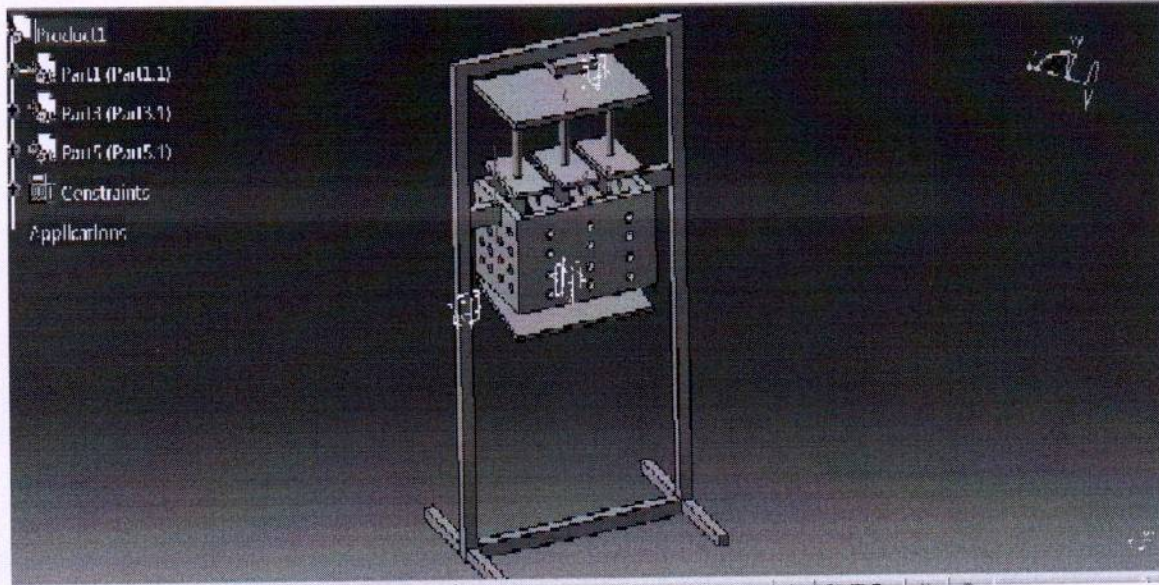

Fig 12: CAD Model Screen Shot2

Conclusion:

The existing crop disease detection system is not appropriate. Therefore, we proposed a quick and accurate solution using mobile phone for detection of crop disease. These project at the initial phase of requirement gathering. Based on the identified problems we have proposed a feasible solution to them.



2.3 NSS Activities



Nirmal Wari



Swaccha Wari



Ganesh Idol Collection



Tree Plantation

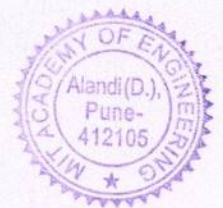

3. Human Values and Professional Ethics

3.1 Students Induction Program (SIP)

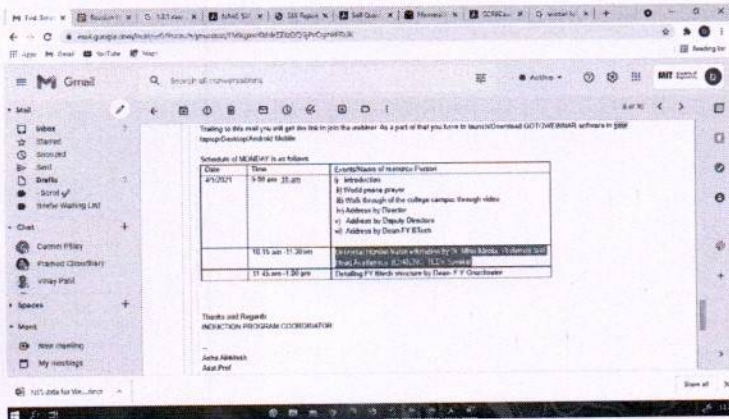

First Year Induction Program Plan



ALL INDIA COUNCIL FOR TECHNICAL EDUCATION
NELSON MANDELA MARG, VASANT KUNJ, NEW DELHI

Certificate of Participation

This is to certify that Mr. Dilip Bharat Panchal from MIT Academy of Engineering, Pune has participated and successfully completed the online workshop on Universal Human Value on the theme "Inculcating Universal Human Values in Technical Education" during 28 September – 2 October, 2020 as organized by All India Council for Technical Education (AICTE).

[Signature]
Dr. Rajneesh Arora
Chairman
National Coordination Committee for Induction Program

[Signature]
Prof. Rajive Kumar
Member Secretary, AICTE

Members Completed the Course

1. Prof. Dilip Panchal
2. Prof. Amol Asalekar
3. Ms. Nandini Phulpagar

5 days Faculty Development Program- Student Induction on UHV Refresher1 (Part 1) conducted online during 23 -27 August, 2021

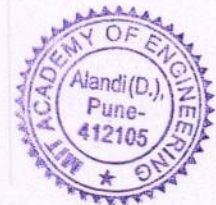

3.2 NSS Organ Donation

MIT | Academy of Engineering
(An Autonomous Institute Affiliated to Savitribai Phule Pune University)

ORGAN DONATION & TRANSPLANT 2K20

18 Oct : 11 AM

ORGANISED BY
NSS | MIT AOE

Registration URL | Scan
<https://attendee.gotowebinar.com/register/1028917893970776334>

LIVE WEBINAR
Save the date
Webinar ID : 183-165-267
18 October | 11 am

CERTIFICATE OF APPRECIATION
for
donors & helpers

SPEAKER GUEST

AARTI GOKHALE
Chief Transplant Co-ordinator for Pune

More than 100 students participated

